



Series EE35

INDUSTRIAL
TRANSMITTER FOR
DEWPOINT MEASUREMENT



MANUAL

Hardware and Software

YOUR PARTNER IN SENSOR TECHNOLOGY



ELEKTRONIK®
Ges.m.b.H.

E+E Elektronik® Ges.m.b.H. doesn't accept warranty and liability claims neither upon this publication nor in case of improper treatment of the described products.

The document may contain technical inaccuracies and typographical errors. The content will be revised on a regular basis. These changes will be implemented in later versions. The described products can be improved and changed at any time without prior notice.

**© Copyright E+E Elektronik® Ges.m.b.H.
All rights reserved.**

USA

FCC notice:

This equipment has been tested and found to comply with the limits for a Class B digital device, pursuant to part 15 of the FCC Rules. These limits are designed to provide reasonable protection against harmful interference in a residential installation. This equipment generates, uses and can radiate radio frequency energy and, if not installed and used in accordance with the installation manual, may cause harmful interference to radio communications. However, there is no guarantee that interference will not occur in a particular installation. If this equipment does cause harmful interference to radio or television reception, which can be determined by turning the equipment off and on, the user is encouraged to try to correct the interference by one or more of the following measures:

- Reorient or relocate the receiving antenna.
- Increase the separation between the equipment and receiver.
- Connect the equipment into an outlet on a circuit different from that to which the receiver is connected.
- Consult the dealer or an experienced radio/TV technician for help.

Caution:

Any changes or modifications not expressly approved by the party responsible for compliance could void the user's authority to operate this device.

CANADIAN

ICES-003 notification:

This Device B digital apparatus complies with Canadian ICES-003.
Cet appareil numérique de la classe B est conforme à la norme NMB-003 du Canada.

TABLE OF CONTENTS

HARDWARE

1. GENERAL	4
1.1 Symbol assertion	4
1.2 Safety instructions	4
1.3 Environmental aspects	5
2. PRODUCT DESCRIPTION	5
3. INSTALLATION	6
3.1 Installation of the housing	6
3.2 Installation of the probe	6
3.2.1 <i>General Safety instructions for installation</i>	6
3.2.2 <i>Installation of the probe directly in the process</i>	7
3.2.3 <i>Installation of the probe by means of the ball valve set</i>	7
4. ELECTRICAL CONNECTIONS	9
4.1 Connection diagram	9
4.2 Connection diagram for alarm module / option	9
4.3 Connection configuration of bottom part of the housing with plug connections 8...35V DC; 12...30V AC (option C03/C07)	9
4.4 Connection configuration for interface cable RS232 / option	9
4.5 Connection configuration of bottom part of the housing with integrated power supply 100...240V AC (option V01)	10
5. OPERATING COMPONENTS	10
5.1 Circuit board	10
5.2 Display module / option	11
6. ALARM MODULE / option	12
7. MAINTENANCE	13
7.1 Sensor replacement	13
7.2 Sensor probe replacement / optional	13
7.3 Fuse replacement	13
7.4 Self diagnosis and error messages	14
7.5 Replacement of sealing element	14
8. REPLACEMENT PARTS / ACCESSORIES	15
9. TECHNICAL DATA	15

CONFIGURATION SOFTWARE

1. GENERAL INFORMATION	16
2. INSTALLATION	16
3. ICONS ON THE TOOLBAR	17
3.1 File	17
3.2 Interfaces	17
3.3 Group	18
3.4 Transmitter	18
3.5 ?-Information	19
4. ICON LIST	19
5. INDEX - INDEX CARDS	20
5.1 Analogue	20
5.2 Relay	20
5.3 Sensor / probe replacement	21
5.4 Calibration	22
5.5 Information	23
6. OVERVIEW	23
6.1 How to set-up a new transmitter?	23
6.2 How to read the configuration of a transmitter?	23
6.3 How to save the configuration in a transmitter?	23

1. GENERAL

E+E Elektronik® has developed this instrument for the exact dewpoint monitoring in industrial applications.

The entire current know how has been invested into the development, construction and production of this instrument.

The manual is a part of the scope of supply and serves to ensure proper handling and optimum functioning of the instrument. For this reason, the manual must be read before start-up.

In addition, the manual is for all personnel who require knowledge concerning transport, setup, operation, maintenance and repair.

The manual must not be used for the purpose of competition without a written consent from E+E Elektronik® and must also not be forwarded to third parties.

Copies for personal use are permitted.

All information, technical data and illustrations contained in these instructions are based on information available at the time of publication.

1.1 Symbol assertion



This symbol indicates a safety instruction.

These safety instructions should always be followed carefully.

By not following these instructions injuries of persons or material damage could happen.

Therefore E+E Elektronik® does not accept liability.



This symbol indicates a note.

These notes should be followed to achieve optimum functioning of the equipment.



1.2 Safety instructions

General Safety Instructions

- Take care when unscrewing the filter cap as the sensor element could be damaged.
- The sensor is an Electro Static Discharge sensitive component (ESD). When touching the sensor element, ESD protective measures should be followed.
- Installation, electrical connection, maintenance and commissioning should be accomplished by qualified personnel only.
- Arbitrary modifications of the product lead to the loss of all warranty claims. This may be accomplished only with an explicit permission of E+E Elektronik®!
- The devices are constructed for the operation of separated extra-low voltage (SELV).



Safety instructions for use of the alarm module with voltages >50V

- To insulate the optional alarm module from the low-voltage side of the transmitter, the partition provided for this purpose must be fitted in the lower section.
- During operation of the instrument the housing must be completely closed.
- The protection class of an opened housing corresponds to IP00 and direct contact with components carrying dangerous voltages is therefore possible. In general, work on live components should be avoided and when absolutely necessary, should be performed by qualified personnel only.



Safety instructions for use of the integrated power supply (option V01)

- During operation of the instrument the housing must be completely closed.
- The protection class of an opened housing corresponds to IP00. In general, work on live components should be avoided and when absolutely necessary, should be performed by qualified personnel only.



1.3 Environmental aspects

Equipment from E+E Elektronik[®] is developed with due consideration to all resultant environmental issues. When you dispose the equipment you should avoid environmental pollution.

For disposal of the transmitter the individual components must be sorted with care. The housing consists of recyclable polycarbonate or metal (aluminium, Al Si 9 Cu 3). The electronics must be collected as electronic scrap and disposed of according to the regulations in force.

2. PRODUCT DESCRIPTION

The EE35 series is based on a functional, user-friendly housing concept and on the proven polymer humidity sensors of the HC series.

A specially developed and in the instrument integrated autocalibration process enables measurements in a range of -60...+60 degC Td (-76...140°F Td) with a accuracy of ± 2 degC Td (36°F Td).

In order to ensure this high accuracy at low humidities, also the smallest drift effects of the humidity sensor element have to be compensated.

Therefore the autocalibration process will be accomplished every 30 minutes and last about 3 minutes. During the autocalibration procedure output signal remains unchanged.

Two freely configurable and scaleable analogue outputs are available for the two measurement values (Td, T). When the dewpoint temperature is below 0 degC (32°F), the transmitter calculates the frostpoint.

An optional hygrostat output, which can be set by means of a potentiometer, provides an alarm signal in a simple way when the threshold of the permitted dewpoint is exceeded.

An optional display for the measurement values and the associated MIN/MAX values allows a quick overview of the current situation.

3. INSTALLATION

3.1 Installation of the housing

The necessary dimensions for mounting the housing can be found in the drawing below.

metal housing:

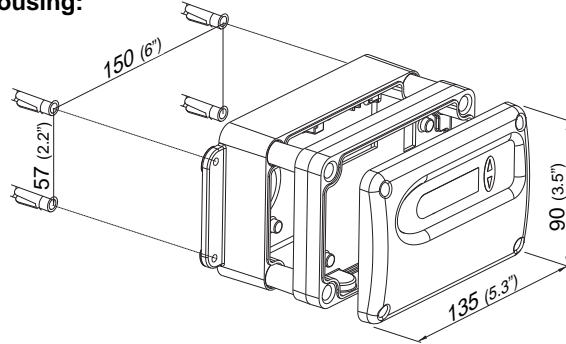

polycarbonate housing:

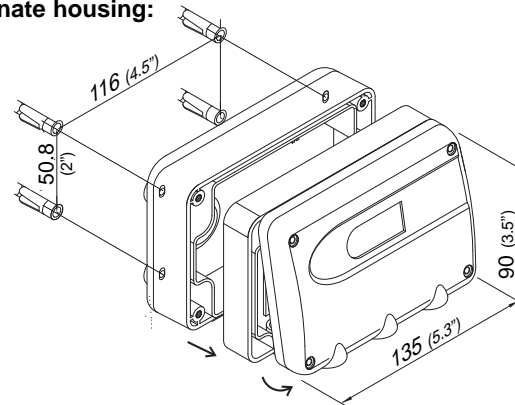

3.2 Installation of the probe

Select a place that is as clean as possible with surrounding conditions that permit an optimal measurement of the process. The air must be able to circulate freely around the sensor element.

3.2.1 General safety instructions for installation



Because the sensing probe can be exposed to very high pressures in the measurement environment, there is the risk of sudden, unintentional expulsion of the probe during or after improper installation. Therefore, special precautions should be followed when working on the sensing probe or in its vicinity. You should not bend directly over the sensing probe under any circumstances!

During the installation of the sensor head, make sure that you do not damage the surface of the sensing probe! Damaging the probe tube could lead to damaged sealing elements (consequence: leakage rate and pressure loss) and to problems during removal (jamming).

Before the sensing probe is installed, make sure that it is free from contaminants (grease, dirt).

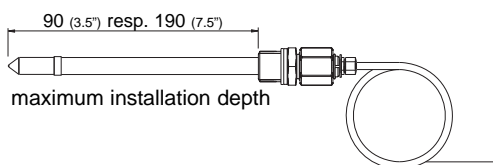
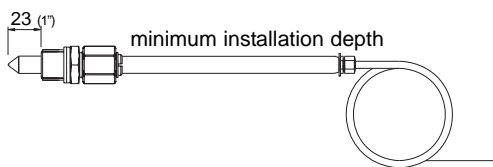
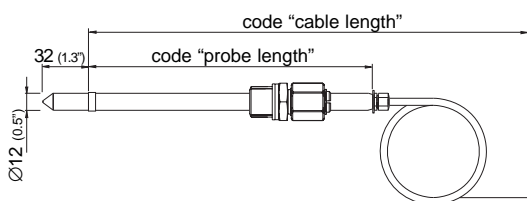

fixed installation
(pressure tight up
to 10bar (145psi))

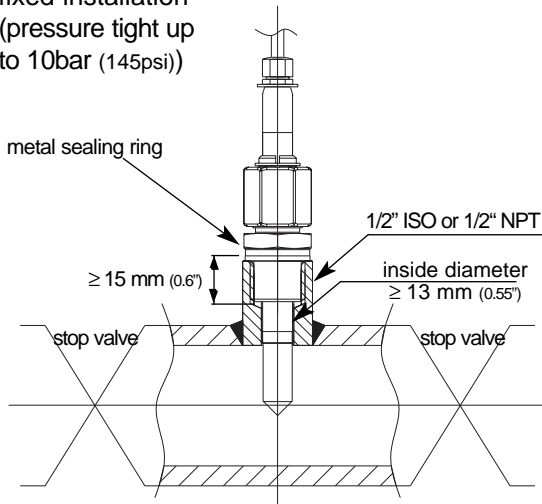

3.2.2 Installation of the probe directly in the process

If the probe is mounted in the measurement chamber, make sure that it is mounted vertically and that the sensor head points downwards.

For direct probe installation, a stop valve should be provided on both sides of the process. This allows the sensor head to be removed for maintenance and calibration without any problems.

If the sensor head is installed in a pressure chamber, make sure that the pressure in the chamber and the ambient pressure are in equilibrium before you remove the probe.

INSTALLATION OF THE PROBE:

1st step:

Mount the probe with the stop valve closed.

2nd step:

Insert the sensor head into the process.

3rd step:

To ensure a secure installation of the probe, the lock nut must be tightened to a defined torque of 30 Nm. If no torque-spanner is available tighten the lock nut by hand as far as possible. Continue to turn with an open-ended spanner ~50°.

3.2.3 Installation of the probe by means of the ball valve set

For a ball valve installation, the system to be measured does not have to be emptied or shut down in order to install or remove the probe.

Install the sensor head perpendicular to the direction of flow.

The pressure of the process must be below 10 bar (145psi).

The two metal sealing rings (see figure) should be changed every time after the probe is unscrewed.

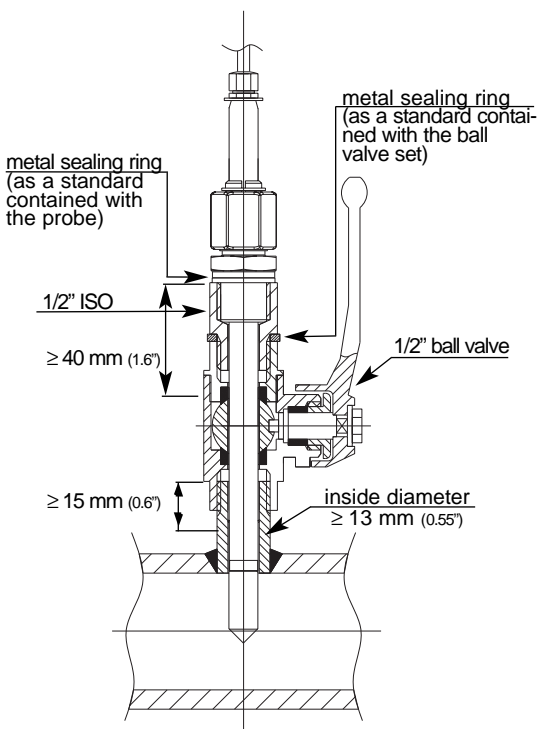

INSTALLATION OF THE PROBE:

1st step:

Mount the probe with the ball valve closed.

2nd step:

Open the ball valve.

3rd step:

Insert the sensor head through the ball valve into the process. A manual pressing tool is recommended at high pressure.

4th step:

To ensure a secure installation of the probe, the lock nut must be tightened to a defined torque of 30 Nm. If no torque-spanner is available tighten the lock nut by hand as far as possible. Continue to turn with an open-ended spanner ~50°.

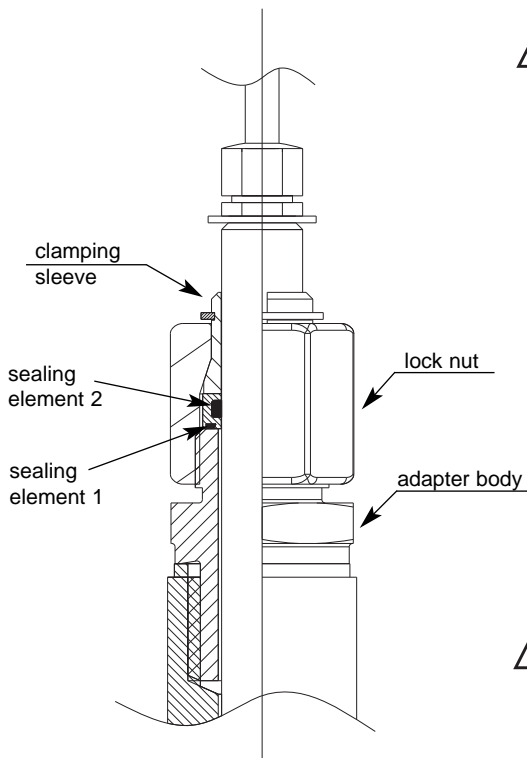

A too low tightening torque results in a smaller tensioning force (fixing force) of the clamping sleeve. There is the risk of injury due to sudden expulsion of the sensing probe. A too high tightening torque can lead to permanent deformation of the clamping sleeve and the sensing probe. This can make the removal and re-installation more difficult or impossible.

REMOVING OF THE PROBE:

1st step:

Firmly hold sensing probe. (Attention: do not bend connection cable)

2nd step:

Slowly loosen the lock nut with a spanner (spanner width 24) until the expulsion force acts on the probe.



In the installed state, never completely remove the lock nut, only unscrew it as much as necessary!

3rd step:

After the sensor head has been pulled out of the process up to the stop, close the ball valve.

4th step:

Probe can now be completely removed.



Pay attention to the sealing element 1 while mounting or removing the probe. This sealing element has to be put in a proper form.

4. ELECTRICAL CONNECTIONS

4.1 Connection diagram

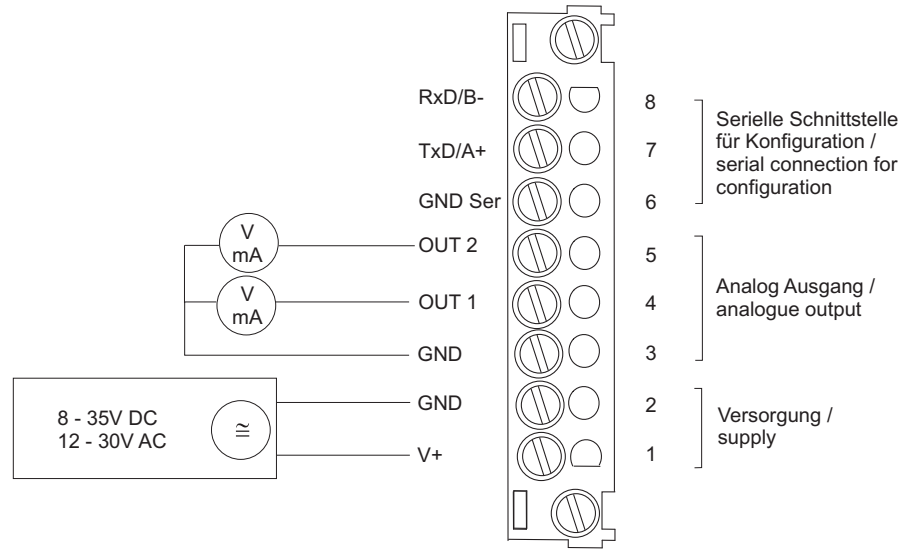

4.2 Connection diagram for alarm module / option

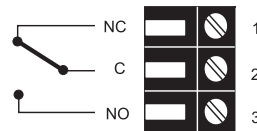

4.3 Connection configuration of bottom part of the housing with plug connections / 8...35V DC; 12...30V AC (option C03/C07)

plug for supply and analogue output
(front view)



Description:

V+
GND
GND
OUT1
OUT2

Connection assignment:

5
4
3
2
1

plug for alarm output
(front view)



Description:

NC
COM
NO

Connection assignment:

1
3
4



The cable should be connected according to the number stamped in the plug as shown in the above drawings!

4.4 Connection configuration for interface cable RS232 / option

Cable:
yellow
brown
white

Description:

GND
TXD
RXD

4.5 Connection configuration of bottom part of the housing with integrated power supply / 100...240V AC (option V01)

plug for RS232 and analogue output
(front view)



Description:	Connection assignment:
RxD / B-	5
TxD / A+	4
GND	3
OUT1	2
OUT2	1

plug for 100-240V metal housing
(front view)



Description:	Connection assignment:
grounding	PE
phase (L1)	1
neutral wire (N)	3

plug for 100-240V polycarbonate housing
(front view)

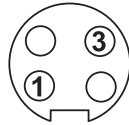

Description:	Connection assignment:
phase (L1)	1
neutral wire (N)	3



External diameter of supply cable: 10-12mm (0.39-0.47")

Maximum wire cross section: 1,5mm² (AWG 16)

The protection of the supply cable against excess current and short-circuit shall be in accordance with national and local codes.

Bottom and centrepiece of the housing shall be grounded!

5. OPERATING COMPONENTS

5.1 Circuit board

After removal of the housing cover, the following operating components on the circuit board may be accessed for adaptation of the transmitter to the desired configuration.

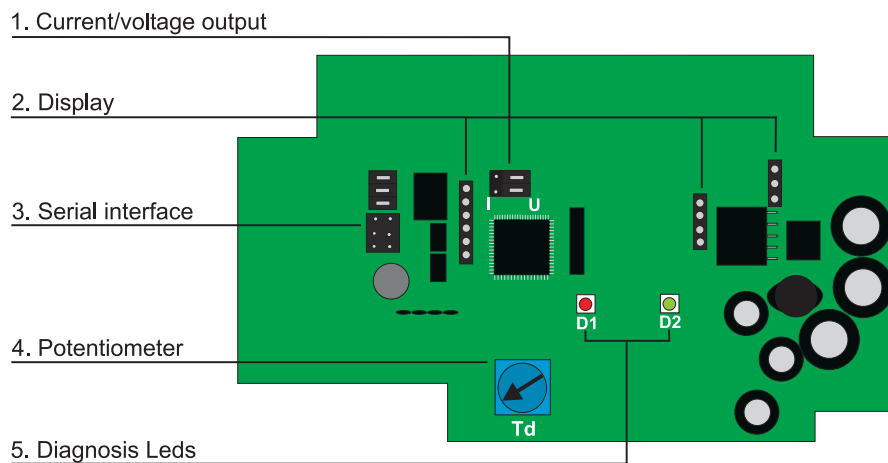

1. Current/voltage output:

When the device will be switched from current to voltage output signals using the configuration software supplied, then two jumpers must also be positioned as follows:

for current signals:  for voltage signals: 

2. Display:

These pinboards are determined for connecting the display module.

3. Serial interface:

Pinboard for serial interface cable.

4. Potentiometer:

In case of installation of the optional alarm module the switching point can be adjusted with the potentiometer.

5. Diagnosis Leds:

Visual indication for easy determination of the error cause.

See Hardware, chapter 7.3 "Self-diagnosis and error messages".

5.2 Display module / option

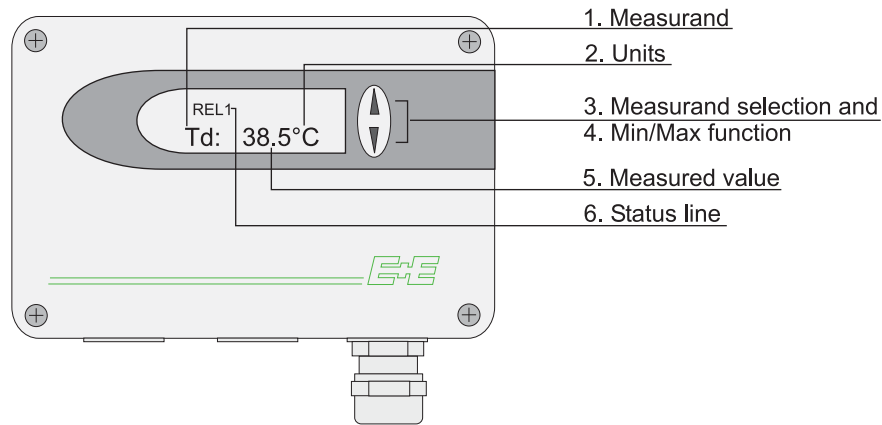

1. Measurand:

SI		SI	US
T	Temperature	°C	°F
Td	Dewpoint temperature	°C	°F
Tf	Frostpoint temperature	°C	°F

3. Measurand selection:

Press the Δ or ∇ button to select between T, Td and Tf.

4. MIN / MAX function:

Transmitters of the EE35 series can display the highest and lowest measured value measured since the last reset.

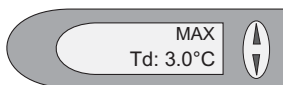

Highest measured value:

1. Select the desired measurand T, Td or Tf.
2. To display the maximum value of the selected measurand press the Δ button for at least five seconds.
- 3.1. To reset the instrument to its normal operating status, press the Δ button once again for five seconds.
- 3.2. If both buttons are pressed for at least five seconds while the maximum value is displayed \rightarrow the "MAX" symbol disappears \rightarrow the maximum value will be deleted (Reset).

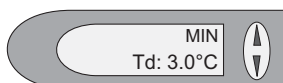

Lowest measured value:

1. Select the desired measurand T, Td or Tf.
2. To display the minimum value of the selected measurand press the ∇ button for at least five seconds.
- 3.1. To reset the instrument to its normal operating status, press the ∇ button once again for five seconds.
- 3.2. If both buttons are pressed for at least five seconds while the minimum value is displayed \rightarrow the "MIN" symbol disappears \rightarrow the minimum value will be deleted (Reset).

5. Measured values:

In this field the measured value of the selected measurand will be displayed.
Measurement range: -70...+60degC (-94...140°F)

6. Status line:

- MIN; MAX
- REL1: Status relay
- "ERROR 01....04": see Hardware, chapter 7.3 "Self-diagnosis and error messages"

6. ALARM MODULE / option

The optional alarm module can be used for alarm and error issues and other simple control functions. The switching point can be set by means of a potentiometer.

min./max. switching point: -60...40°C Td (-60...40°F Td)

max. switched voltage / max. switched current: 250V AC / 6A

28V DC / 6A

Minimum load: >100mA / 12V



If relay has tripped (ON), then REL1 is displayed.

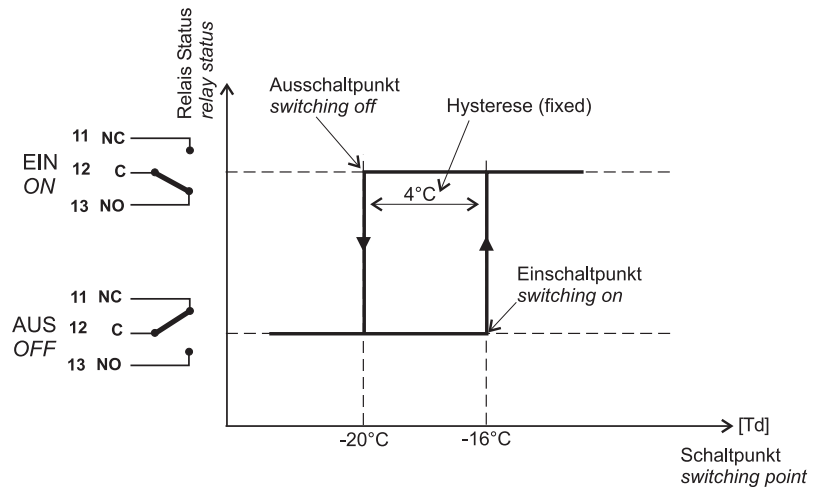

7. MAINTENANCE

7.1 Sensor replacement

Under certain circumstances, the capacitive humidity sensor element can get damaged. To avoid the costly return of the entire transmitter to the manufacturer it is possible to replace the sensor.



Comments:

- This will invalidate the factory calibration.
- The sensor elements should be touched by the lead wires only. (use tweezers!)

Sensor replacement procedure:

- 1) Switch off supply voltage.
- 2) Unscrew the filter cap.
- 3) Pull out the humidity/temperature sensor element with a tweezer.
- 4) Put in the new humidity sensor - the active side (side with the sensor pads) has to face the outside. (see diagram)
- 5) Put in the temperature sensor.
- 6) Screw on the filter cap. (in case of pollution replace it by a new filter cap)
- 7) Establish connection to PC. (RS232)
- 8) Switch on the supply voltage.
- 9) Start configuration software on PC.
- 10) For further instructions, see Configuration software, chapter 5.3 "Sensor/Probe replacement"

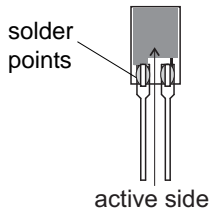

7.2 Sensor probe replacement / optional

Transmitters of the EE35 series are available with an optional remote sensor probe that can be plugged into the middle section of the housing. If the sensor probe is damaged (damage to the cable, mechanical destruction of the sensor probe) it is possible to replace the probe.

Note:

This will invalidate the factory calibration.

Sensor probe replacement procedure:

- 1) Switch off supply voltage.
- 2) Remove damaged sensor probe.
- 3) Plug replacement probe onto middle part of the housing.
- 4) Establish connection to PC (RS232).
- 5) Switch on power supply voltage.
- 6) Start configuration software on PC.
- 7) For further instructions, see Configuration software, chapter 5.3 "Sensor/Probe replacement"



7.3 Fuse replacement

If the green LED on the PCB is not flashing with the supply voltage switched on, check the fuse and replace if required.

Fuse secondary: 250mA / T UL248-14

Nominal voltage: 250V

Replacement types:

Series: MSTU 250 Manufacturer: Schurter Order No.: 0034.7109

Series: 374 Manufacturer: Littelfuse Order No.: 374 0250

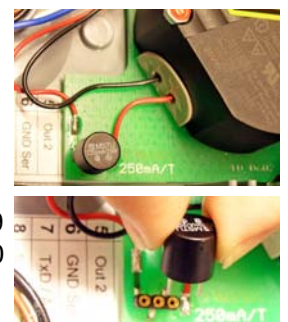

Hardware

7.4 Self diagnosis and error messages

Self diagnosis via LEDs on the circuit board:

- **Green LED**
flashing ⇒ Supply voltage applied / Microprocessor is active
- **Red LED**
constantly lit ⇒ Humidity sensor element damaged
flashing ⇒ Humidity sensor element accruing moist (condensation!) or
short flashing approx. 20 sec. ⇒ warm up phase during the auto calibration

Self diagnosis via display (where available):

- Error 1 ⇒ Humidity sensor element damaged
- Error 2 ⇒ Humidity sensor element moistened (condensation!)
- Error 3 ⇒ Temperature sensor element damaged
- Error 4 ⇒ Short circuit of temperature sensor

Definitions:



- **Errors**
Possible cause
⇒ *Measures / help*
- **Display shows incorrect values**
Filter soiled
⇒ *Replace filter*
Sensor defect
⇒ *Replace sensor*
- **Transmitter failure**
No supply voltage
⇒ *Check wiring and supply voltage*
⇒ *Only green LED is illuminated continuously ⇒ Electronics defect ⇒ contact the manufacturer.*
- **High humidity values - red LED blinks**
Dew (condensation) in sensor probe head
⇒ *Dry probe head and check the sensor probe mounting type*
Incorrect filter type (e.g. storage of humidity after stainless steel sintered filter condensation)
⇒ *Filter type should match the application*

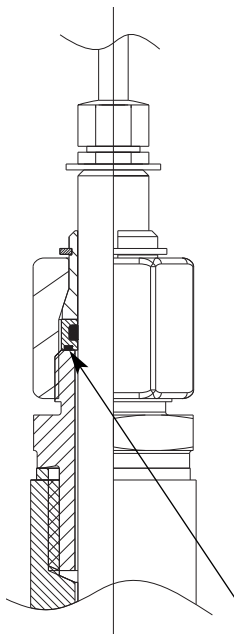

7.5 Replacement of sealing element

Because of repeated installations and various other circumstances the sealing element can get damaged. The customer can do a replacement of this sealing element (refer to drawing).

8. REPLACEMENT PARTS / ACCESSORIES

Description	Order code
- Sintered stainless steel filter	HA 010103
- Display + housing cover in metal	D05M
- Display + housing cover in polycarbonate	D05P
- Bracket for fixing onto mounting rails	HA 010203
- Ball valve set	HA 050101
- Replacement probe with 1m cable	HA 050201
with 2m cable	HA 050202
with 5m cable	HA 050203
with 10m cable	HA 050204
- Sealing element	HA050309
- Interface cable	HA010304

9. TECHNICAL DATA

Measuring Quantities

Dew point

Humidity sensor

HC1000-400

Measuring range

standard calibration: -40...60°C (-40...140°F)

(below 0°C / 32°F the transmitter outputs frostpoint)

special calibration: -60...60°C (-76...140°F)

Accuracy

≤ ±2°C (≤ ±3.6°F)

Traceable to intern. standards,
adminstrated by NIST, PTB, BEV...

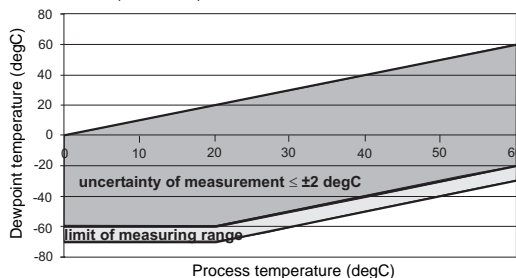

Response time t_{90}

80 sec. -20°C → -40°C (-4°F → -40°F)
10 sec. -40°C → -20°C (-40°F → -4°F)

Temperature

Sensor

Pt1000 DIN A

Measuring range

0...60°C (32...140°F)

Accuracy of temperature measurement at 20°C (68°F)

±0.2°C (±0.36°F)

Sensitivity error at full scale

±0.1°C (±0.18°F)

Temperature dependence of electronics

< 0.005°C/°C

Outputs

Two freely selectable and scaleable analogue outputs
xx...yy°C T, Td/Tf / xx...yy°C respectively

0 - 5V

0 - 10V

4 - 20mA

0 - 20mA

General

Supply voltage

8...35V DC

12...30V AC

(optional 100...240V AC, 50/60Hz)

Current consumption

- voltage output

typ. 40mA, with autocalibration: 100mA

- current output

typ. 80mA, with autocalibration: 140mA

Pressure range

0...10bar (0...145psi)

Housing / protection class

PC or Al Si 9 Cu 3 / IP65; Nema 4

Cable gland

M16 x 1.5 (option: plug) cable Ø 4.5 - 10 mm (0.18 - 0.39")

Electrical connection

screw terminals up to max. 1.5mm² (AWG 16)

Sensor protection

stainless steel sintered filter

Working temperature range

probe: -40...60°C (-40...140°F)

electronic: -40...60°C (-40...140°F)

with LC display: -20...50°C (-4...122°F)

with alarm module: -40...60°C (-40...140°F)

Storage temperature range

-40...60°C (-40...140°F)

Electromagnetic compatibility according to

EN61326-1:1997 + note1:1998

FCC Part15 ClassB

ICES-003 ClassB



Technical Data for Options

Display

graphical LC display (128x32 pixels), with integrated push-buttons for selecting parameters Td or T and MIN/MAX functions

Alarm output for Td/Tf

- range: -60...40°C Td (-60...40°F Td) adjustable with the potentiometer on the printed circuit board
- 1 switch contact
- 250V AC/6A or 28V DC/6A

CONFIGURATION SOFTWARE

LIMITED LIABILITY

E+E Elektronik® is not liable for any damages or consequential damages (for example, but not restricted to loss of earnings, interruption of business, loss of information and data or any other pecuniary damages), that result from the installation, usage and also impossibility of usage of a software product from E+E Elektronik® and supportservices possibly associated with it or non-performance of support.

1. GENERAL INFORMATION

The configuration software was developed by E+E Elektronik® Ges.m.b.H to allow fast and easy configuration of individual transmitters.

This software tool is included in the scope of supply.

System requirements: MS WINDOWS 98® or higher; RS232 serial interface

2. INSTALLATION

Insert the CD-ROM supplied with the transmitter into the PC and open the set-up application. Follow the instructions of the dialogue menus to set the desired language and all other parameters for installation. At the end of the routine, the software is installed and the Readme file or the program will be automatically opened.



Note:

Before any reinstallation or upgrade the older version must first be uninstalled (the User will be notified during the installation routine and the process will be interrupted automatically).

To remove the previous version, open the software folder in the system control panel. All of the programs installed on your system are located here. Uninstall the EE35 Configurator by clicking on the appropriate button and then reinstall or upgrade.

Connection for serial interface (HA010304):

Refer to chapter 5.1 "Circuit board".

3. ICONS ON THE TOOL BAR

3.1 File

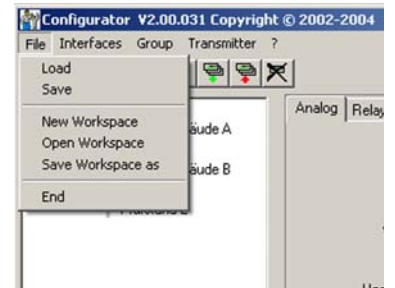

Load: Loads a file with a saved transmitter configuration.

Save: Saves the current transmitter configuration in a file.

New Workspace: Opens a file for a new tree.

Open Workspace: Opens existing trees.

Save Workspace: Saves the current trees in an archive file.



Note:

The functions "Save Workspace" and "Open Workspace" apply to the tree structure only, not to the configurations of individual transmitters!

3.2 Interfaces

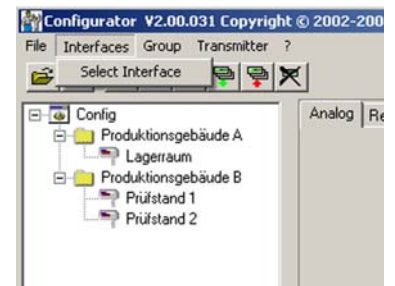

Select: Selects the serial interface (COM port) for communication with the transmitters. Following functions are available:

use / do not use: Marked COM ports are greyed out and deactivated for the configuration software (e.g. COM for integrated Notebook Modem).



Note:

A disabled interface (shaded = do not use), can be enabled by clicking on the "use" button.

3.3 Group

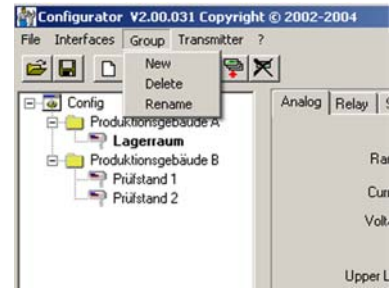

The icon "Group" provides the option of combining transmitters in groups. A group may consist of transmitters used in the same application, for instance assigned to a building.

New: Creates a group or adds another group into an existing structure.

Delete: Deletes groups within a tree.

Rename: Changes the name of a transmitter group.

3.4 Transmitter

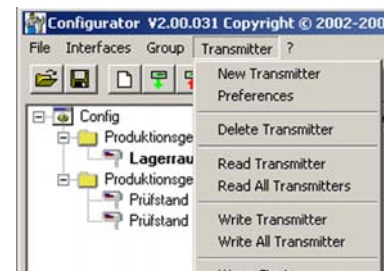

New transmitter:



A new transmitter is created in the tree. This procedure requires the input of a number of parameters:

Group: Assigns a transmitter to a group.

Network: This function is not available for the EE35 series.

Interface: Selects the interface for connecting the transmitter to the network. (For information on how to set up a COM port, see Configuration Software, chapter 3.2 "Interfaces").

Network address: This function is not available for the EE35 series.

Name: Assigns a meaningful name related to the transmitter. This name is displayed in the tree under the relevant group (e.g.: Clean Room).









- Preferences:** Displays the preferences for all transmitters that have been set-up. The preferences may also be changed here.
- Delete transmitter:** Deletes from the tree structure the selected transmitters, or the selected groups.
- Read:** Reads and displays the configuration parameters of the selected transmitter.
- Read All:** This function is not available for the EE35 series.
- Write:** Writes the current configuration to the selected transmitter.
- Write All:** This function is not available for the EE35 series.
- Warm Start:** Resets and restarts the microprocessor of the selected transmitter.

3.5 ? - Information

- Version:** Displays the version number of the EE35 configuration software currently installed and the contact information for E+E Elektronik.

4. ICON LIST



-  "Load File" (see Configuration Software, chapter 3.1 File)
-  "Save File" (see Configuration Software, chapter 3.1 File)
-  "New Transmitter" (see Configuration Software, chapter 3.4 Transmitter)
-  "Read Transmitter" (see Configuration Software, chapter 3.4 Transmitter)
-  "Save Transmitter" (see Configuration Software, chapter 3.4 Transmitter)
-  This function is not available for the EE35 series.
-  This function is not available for the EE35 series.
-  "Delete Transmitter" (see Configuration Software, chapter 3.4 Transmitter)

5. INDEX - INDEX CARDS

5.1 Analogue

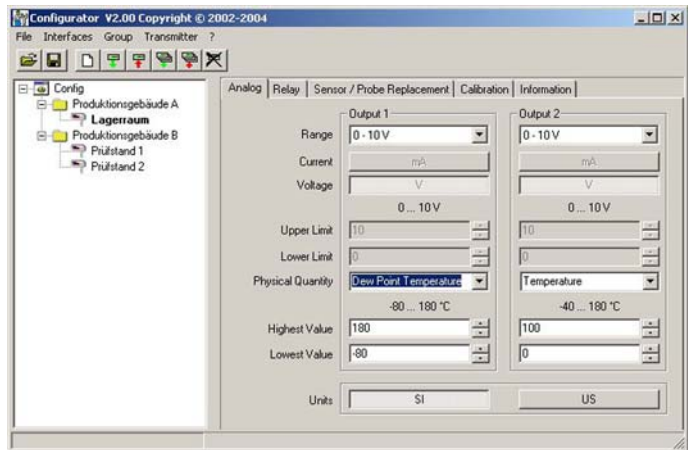

For the configuration of both analogue outputs.

Range: Using the drop-down input field, select either a standardized output signal (0-5V, 0-10V, 0-20mA, 4-20mA) or a user-defined current/voltage output range (upper and lower limits may be selected as required between the limits indicated).

Physical Quantity: Selects the output physical quantities.

Highest / Lowest Limit: Sets the desired scaling of the output. The limits must fall within the operating range indicated above.

Units: Selects between SI or US units.

5.2 Relay

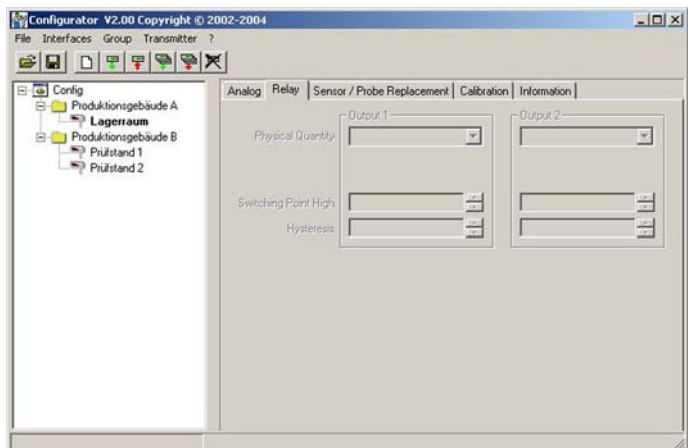

The configuration of the relay is possible on the PCB.

5.3 Sensor / Probe Replacement

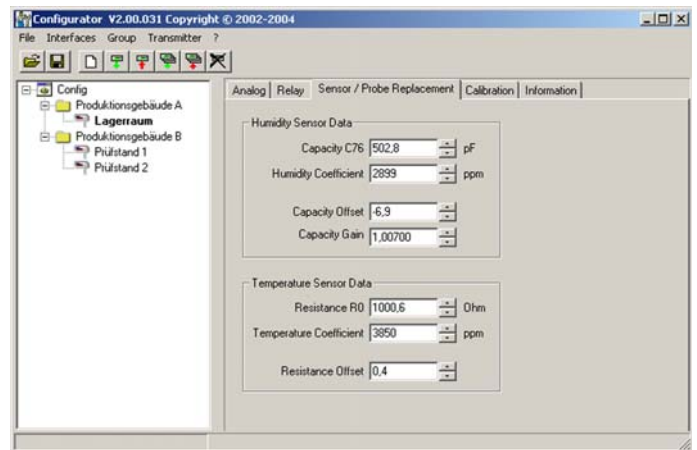

In case of sensor or probe replacement, the characteristic values for this sensor/probe must be saved in the transmitter to ensure the transmitter will operate within the specified accuracy range.

- Replacement - Humidity Sensor:
- 1) Open the configuration of the selected transmitter by clicking on the button "Read Transmitter".
 - 2) Replace the humidity sensor by a new one (see Hardware, chapter 7.1 Sensor Replacement).
 - 3) Enter the nominal capacity C76 and the humidity coefficient in the corresponding input fields.
 - 4) Save the settings by clicking on the button "Save Transmitter".

- Replacement - Probe:
- 1) Open the configuration of the selected transmitter by clicking on the button "Read Transmitter."
 - 2) Replace the probe by a new one (see Hardware, chapter 7.2 Probe Replacement).
 - 3) Enter the nominal capacity C76, the humidity coefficient, the offset, the gain, the resistor R0, the temperature coefficients, and the resistor offset in the corresponding input fields.
 - 4) Save the settings by clicking on the button "Save Transmitter."

5.4 Calibration

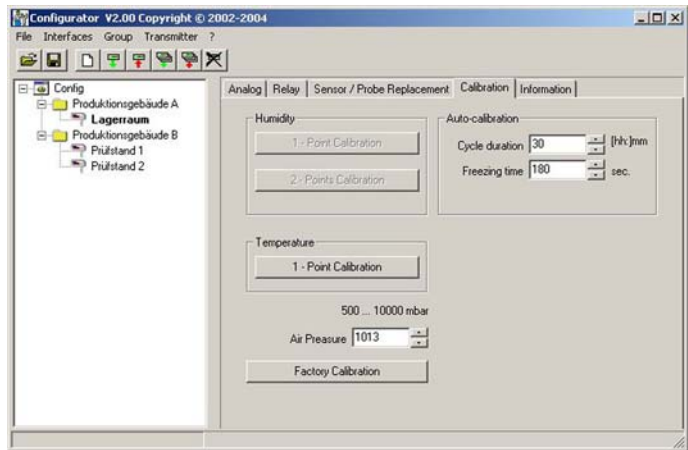

Auto Calibration:

cycle duration: defines the time slice of the auto calibration.

freezing time: defines the time how long the analogue resp. display values can be kept during the auto calibration.

1-point calibration Humidity:

This function is not available for the EE35 series.

2-point calibration Humidity:

This function is not available for the EE35 series.

1-point calibration Temperature:

If the working range is limited to a narrow temperature range, one-point calibration will be sufficient within this working range.

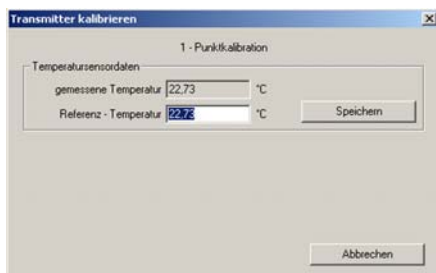

- 1) Place the probe at the reference temperature and allow stabilisation for approx. 30 minutes.
- 2) Click on the Temperature 1-Point Calibration button.
The measured value will appear in both input fields. (see additional window)
- 3) Replace the value in the input field "Temperature Reading" with the reference temperature.
- 4) By clicking on "Save", the temperature reading of the transmitter will be adjusted to the reference temperature.
- 5) The process is complete when the message "Calibration Successful" appears.

5.5 Information

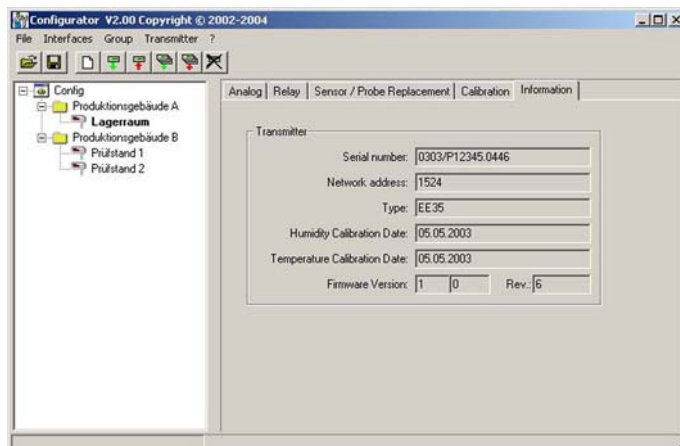

Here you will find information on the selected transmitter.

Serial number:

Used to track the manufacturing data of the transmitter.

Network address:

Each transmitter is assigned a unique network address at the factory for precise identification.



Note:

This identification number is also issued for transmitters of the EE35 series, although transmitters of this series are not network compatible.

Type:

Name of the transmitter series.

Humidity Calibration Date:

Provides information on the date of the last humidity calibration.

Temperature Calibration Date:

Provides information on the date of the last temperature calibration.

Firmware / Version:

Provides information on the software version implemented in the transmitter (internal).

6. OVERVIEW

6.1 How to set-up a new transmitter?

Menu "File" --> "New Workspace"

Assign a name to the file and select the location to save the file

Menu "Group" --> "New Group"

Assign and add a name, then click on "Finish"



Menu " Transmitter" --> "New Transmitter" or Button "New Transmitter"

Select the group for the transmitter using the pull-down menu "Group."

Specify the COM port (serial interface) of the PC / Notebook in the pull-down menu "Interface".

Enter the name for the transmitter in the "Name" field.

Complete the "New Transmitter" process by clicking on the button "Add".

6.2 How to read the configuration of a transmitter?



The current configuration of the selected transmitter can be read by clicking on the button "Read Transmitter" or by selecting "Transmitter" --> "Read Transmitter."

If the configuration is already loaded, the configuration data in the Index- index cards can be modified.

6.3 How to save the configuration in a transmitter?



A modified configuration in the Index - index cards can be saved to the selected transmitter by clicking on the button "Save Transmitter" or by selecting "Transmitter" --> "Save Transmitter."

HEAD OFFICE:

E+E ELEKTRONIK Ges.m.b.H.
Langwiesen 7
A-4209 Engerwitzdorf
Austria
Tel: ++43/7235/605-0
Fax: ++43/7235/605-8
info@epluse.com

TECHNICAL OFFICES:

E+E CHINA

B0820, Hui Bin Office Building,
No. 8, Bei Chen Dong St., Chao Yang District,
Beijing 100101, P.R. China
Tel: ++86/10/84992361; ++86/10/84992362
Fax: ++86/10/84992363
info@epluse.cn

E+E FRANCE

Le Norly III; 136 chemin du Moulin Caron
F-69130 Ecully
Tél : ++33/4 7472 35 82
Fax : ++33/4 7833 44 39
info@epluse.fr

E+E GERMANY

Schöne Aussicht 8c
D-61348 Bad Homburg
Tel: ++49/6172/13881 0
Fax: ++49/6172/13881 26
info@ee-elektronik.de

E+E KOREA

24-1 Gumi-Dong, Bundang-Ku, Seongnam-
Si, Kyeonggi-Do (ROK)
463-808, #512 Hyundai-Venturevill
Tel: ++82/31/728 2223
Fax: ++82/31/728 2224
info@epluse.co.kr